

This publication assists applicants for Year 7 entry to selective high schools to become more familiar with the Selective High School Placement Test. Some of the items have not been included for copyright reasons. In the actual Selective High School Placement Test there are 45 questions in reading, 40 in mathematics and 60 in general ability.

The Selective High School Placement Test measures ability and is set to discriminate at a very high level. Students who are accustomed to answering most questions in tests correctly should not be discouraged if they get a number of questions wrong. It is very rare for even the highest scoring candidates to score full marks on all components of the Selective High School Placement Test.

Selective high school entry does not depend entirely on a student's performance in the Selective High School Placement Test as school assessment scores in English and mathematics are provided by the primary schools.

It is important to note that selection committees and appeals panels will not accept students' performance in this past paper as evidence of academic merit for the purposes of entry into a selective high school in any future year.



SELECTIVE HIGH SCHOOL PLACEMENT TEST

Mathematics sample test 1

INSTRUCTIONS

1. There are 38 questions in this sample set. You have 40 minutes to complete the real test which contains 40 questions.
2. With each question there are four possible answers **A**, **B**, **C** or **D**. For each question you are to choose the **ONE** answer you think is best. To show your answer, fill the oval for one letter (**A**, **B**, **C** or **D**) on the separate answer sheet in the section headed Mathematics.
3. If you decide to change an answer, rub it out completely and mark your new answer clearly.
4. If you want to work anything out you may write on the question booklet.
5. If you need the help of the supervisor during the test, raise your hand.

- 1 Lena is tiling a square floor with each side 3 metres long. Tiles cost \$45 per square metre.

Which calculation gives the total cost of tiling the floor (in dollars)?

- A 45×6
- B 45×9
- C $45 \div 6$
- D $45 \div 9$

2

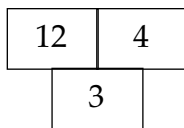

If the pattern in the three boxes above is repeated in the three boxes below

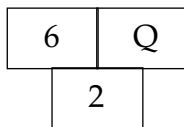

then $Q =$

- A 2
 - B 3
 - C 4
 - D 12
- 3 When George and Athena were married, 120 of the guests were Athena's family or friends. This was 60 per cent of the total number of guests.
- How many guests were there altogether?
- A 180
 - B 192
 - C 200
 - D 720

Questions 4–6 refer to the following information:

This is part of the timetable for the bus to the city.

| Stop number | BUS TIMES TO THE CITY | | | | | | | | | |
|-------------|-----------------------|------|------|------|------|------|------|-------|--|--|
| 1 (Depot) | 6:50 | 7:10 | 7:30 | 7:50 | 8:10 | 8:30 | 9:00 | 9:30 | | |
| 2 | 6:55 | 7:15 | 7:35 | 7:55 | 8:15 | 8:35 | 9:05 | 9:35 | | |
| 3 | 6:58 | 7:18 | 7:38 | 7:58 | 8:18 | 8:38 | 9:08 | 9:38 | | |
| 4 | 7:04 | 7:24 | 7:44 | 8:04 | 8:24 | 8:44 | 9:14 | 9:44 | | |
| 5 | 7:07 | 7:27 | 7:47 | 8:07 | 8:27 | 8:47 | 9:17 | 9:47 | | |
| 6 | 7:10 | 7:30 | 7:50 | 8:10 | 8:30 | 8:50 | 9:20 | 9:50 | | |
| 7 | 7:15 | 7:35 | 7:55 | 8:15 | 8:35 | 8:55 | 9:25 | 9:55 | | |
| 8 | 7:19 | 7:39 | 7:59 | 8:19 | 8:39 | 8:59 | 9:29 | 9:59 | | |
| 9 | 7:22 | 7:42 | 8:02 | 8:22 | 8:42 | 9:02 | 9:32 | 10:02 | | |
| 10 | 7:26 | 7:46 | 8:06 | 8:26 | 8:46 | 9:06 | 9:36 | 10:06 | | |
| 11 | 7:31 | 7:51 | 8:11 | 8:31 | 8:51 | 9:11 | 9:41 | 10:11 | | |
| 12 | 7:33 | 7:53 | 8:13 | 8:33 | 8:53 | 9:13 | 9:43 | 10:13 | | |
| 13 | 7:36 | 7:56 | 8:16 | 8:36 | 8:56 | 9:16 | 9:46 | 10:16 | | |
| 14 | 7:38 | 7:58 | 8:18 | 8:38 | 8:58 | 9:18 | 9:48 | 10:18 | | |
| 15 (City) | 7:41 | 8:01 | 8:21 | 8:41 | 9:01 | 9:21 | 9:51 | 10:21 | | |

- 4** Kylie can walk from home to bus stop number 6 in eight minutes.
- What is the latest time she can leave home to be sure of getting to the city by 8:30?
- A** 7:22
B 7:42
C 7:50
D 8:02
- 5** Peter travels from stop number 8 to the city each morning. His return journey each evening takes the same time as his morning bus ride.
- If he leaves the city at 5:41 pm what time will he reach stop number 8?
- A** 5:19 p.m.
B 6:03 p.m.
C 6:19 p.m.
D 7:03 p.m.
- 6** Which one of these statements about the bus timetable is correct?
- A** The longest time between stops is 5 minutes.
B The total trip from the depot to the city always takes 61 minutes.
C From 8:30 onwards it takes 10 minutes longer to get from the depot to the city.
D From 8:30 onwards it is 10 minutes longer between buses leaving the depot.

- 7 The numbers 1, 2, 3, 4, 5, 6, 8, 9, 10 and 12 can be arranged around this star so that the sum along each straight line is the same. Four of the numbers are missing.

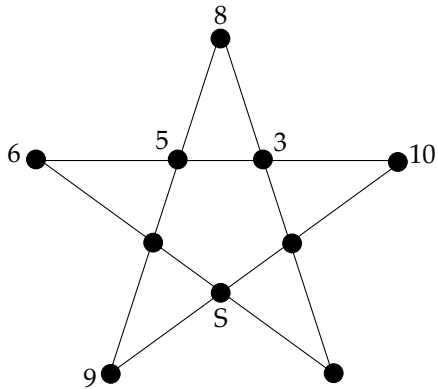

The number missing at S is

- A 1
 B 2
 C 4
 D 12
- 8 A piece of cardboard is folded to make six strips the same size. The strips are numbered as shown. The cardboard is bent along the folds and joined to make a hexagonal tube.

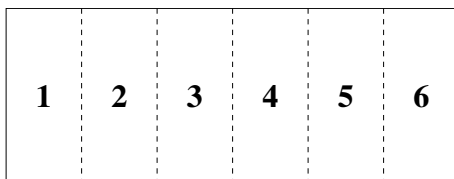

When the tube is made the side numbered 6 is opposite the side numbered

- A 1
 B 2
 C 3
 D 4

- 9 Rita and Minh look at some blocks from opposite sides.

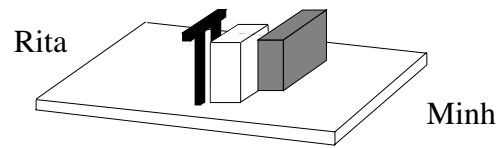

Minh sees



What does Rita see?

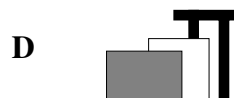
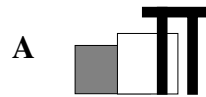

- 10 Irene's grandfather arrived in Sydney from Athens at 10 pm on Friday after a 25-hour trip. The flight began at 12 noon on Thursday, Athens time.

What is the time difference between Athens and Sydney?

- A Athens time is 9 hours behind Sydney time.
 B Athens time is 9 hours ahead of Sydney time.
 C Athens time is 15 hours behind Sydney time.
 D Athens time is 15 hours ahead of Sydney time.

Questions 11–13 refer to the following information:

The following chart is called a Vedic Square. Each number in the chart is found by multiplying the number at the top of its column by the number at the left of its row.

When a product has more than one digit in it, these are added to give a single digit. For example, $8 \times 2 = 16$; $1 + 6 = 7$.

| | 1 | 2 | 3 | 4 | 5 | 6 | 7 | 8 | 9 |
|---|---|---|---|---|---|---|---|----------|---|
| 1 | 1 | 2 | 3 | 4 | 5 | 6 | 7 | 8 | 9 |
| 2 | 2 | 4 | 6 | 8 | 1 | 3 | 5 | 7 | 9 |
| 3 | 3 | 6 | 9 | 3 | 6 | 9 | 3 | 6 | |
| 4 | 4 | 8 | 3 | 7 | 2 | 6 | 1 | | |
| 5 | 5 | 1 | 6 | 2 | | | | | |
| 6 | 6 | 3 | 9 | 6 | | | | | |
| 7 | 7 | 5 | 3 | 1 | | | | | |
| 8 | 8 | 7 | 6 | | | | | P | 9 |
| 9 | 9 | 9 | | | | | | 9 | |

- 11** The Vedic Square shown is incomplete. The number missing at **P** is
- A** 0
 - B** 1
 - C** 2
 - D** 7

- 12** The complete pattern for row 7 is
- A** 7 5 3 1 2 4 6 8 1
 - B** 7 5 3 1 7 5 3 1 7
 - C** 7 5 3 1 8 6 4 1 9
 - D** 7 5 3 1 8 6 4 2 9

Information for Question 13

Scholars and artists use this Vedic Square to draw a design. A row of numbers and an angle of rotation are selected. Each number in the row gives the length of the line to be drawn.

For example, using an angle of rotation of 90 degrees and the number sequence in row 3 gives:

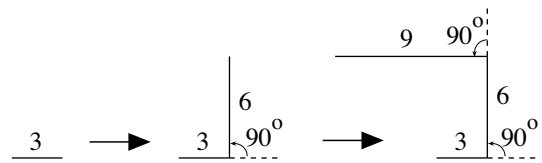

Continuing this sequence of numbers and rotation leads eventually to this design.

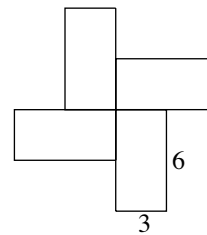

Different designs result when a different angle of rotation or a different row from the Vedic Square is chosen.

- 13** Which row was used to create this design?

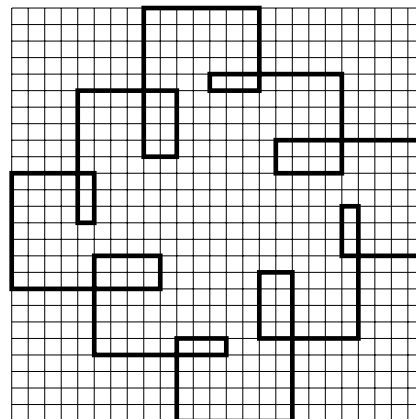

- A** row 2
- B** row 4
- C** row 6
- D** row 8

Questions 14–15 refer to the following information:

The numbers 1, 7, 19, 37, . . . are sometimes called *snowflake numbers* because they can be pictured as a pattern of dots, like this:

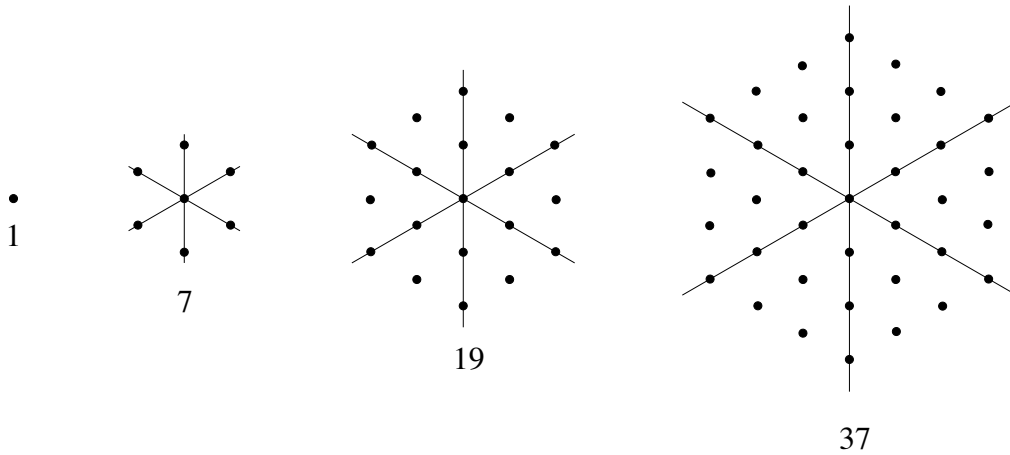

A second number sequence is obtained by counting the number of dots on the lines shown in the pictures.

| | snowflake number (number of dots) | number of dots on the lines |
|--------|--------------------------------------|--------------------------------|
| first | 1 | – |
| second | 7 | 7 |
| third | 19 | 13 |
| fourth | 37 | 19 |
| fifth | ? | ? |

14 The fifth snowflake number is

- A 49
- B 55
- C 61
- D 67

15 How many dots on the lines would there be in a picture showing the fifth snowflake number?

- A 19
- B 25
- C 31
- D 37

Questions 16–18 refer to the following information:

The air above the Earth’s surface is divided into different layers. The temperature of the air at different heights above sea level and the positions of the different layers are shown in this graph.

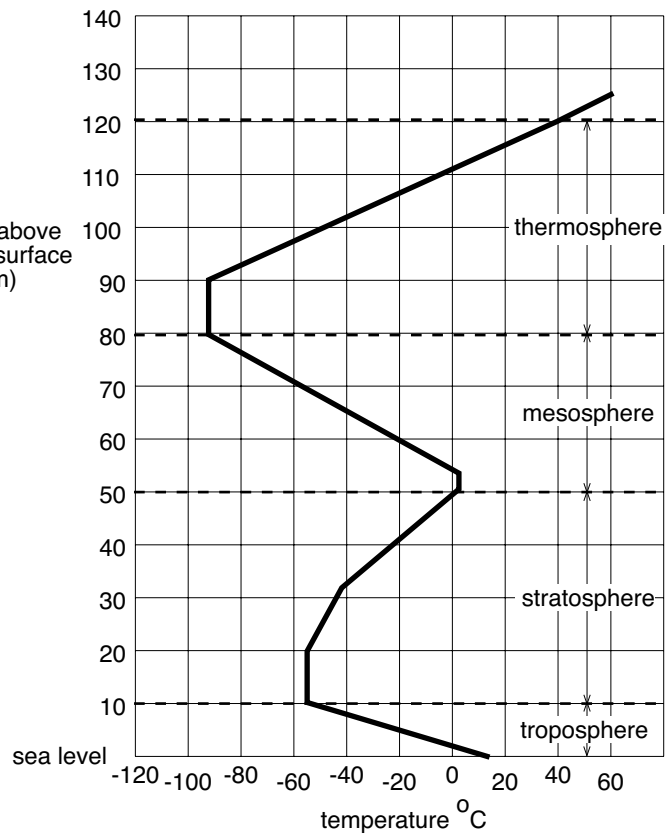

- 16 What is the approximate air temperature 40 km above sea level?
- A 33°C
 - B 20°C
 - C -20°C
 - D -33°C
- 17 According to the graph, if the temperature is -60°C, the height above sea level is
- A -25 km.
 - B 85 km.
 - C either 77 km or 93 km.
 - D either 71 km or 98 km.
- 18 According to the graph the lowest temperature normally reached in the mesosphere is
- A 105°C.
 - B 50°C.
 - C 2°C.
 - D -95°C.

- 19 The number pattern in triangle **P** is repeated in triangle **Q**.

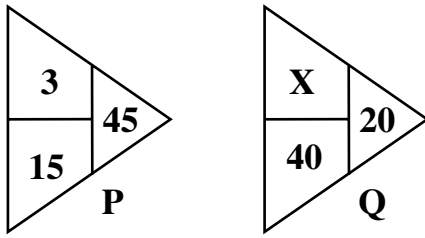

What is the value of **X**?

- A $\frac{1}{2}$
 B 2
 C 3
 D 20
- 20 Four children each made a pattern by folding paper and punching holes through all the layers.
 Here is Duong's pattern.

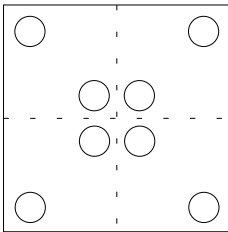

Which one of these is Duong's folded paper?

A

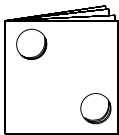

C

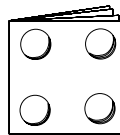

B

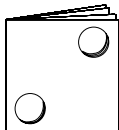

D

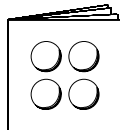

- 21 $204 \div 102 = \Delta \div 204$.

$\Delta =$

- A 2
 B 51
 C 102
 D 408

- 22 The area of this door

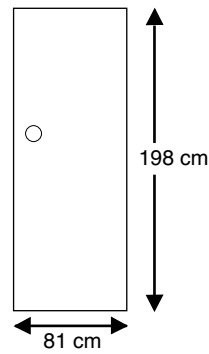

in square centimetres (cm^2), is about

- A 280 cm^2 .
 B 560 cm^2 .
 C $1\ 600 \text{ cm}^2$.
 D $16\ 000 \text{ cm}^2$.

Questions 23–24 refer to the following information:

The lines on this graph give a way to convert between the metric system of length units and the British system of length units. The metric system uses units of centimetres, metres and kilometres. The British system uses units of inches, yards and miles. For example, point X on the graph shows that 80 metres in metric units is 88 yards in British units.

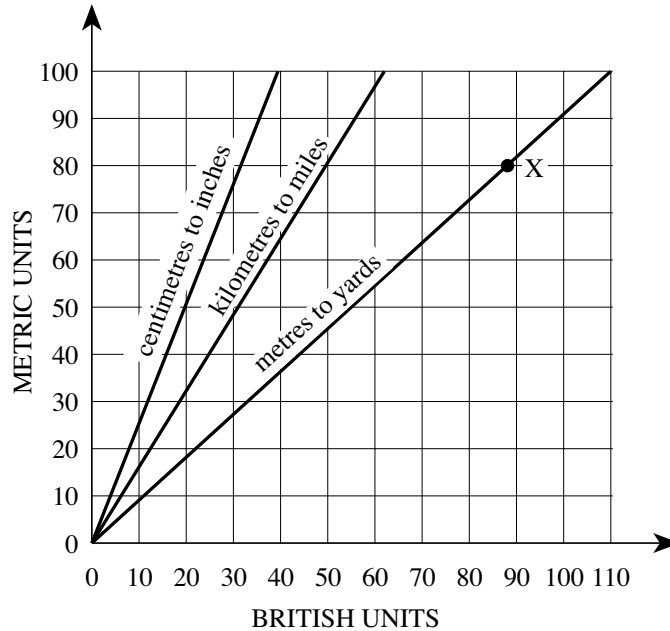

- 23** An English tourist has a map which shows the distance from Gosford to Hornsby as 40 kilometres.

The graph shows that this distance in British units is

- | | |
|--------------------|---------------------|
| A 25 miles. | C 65 miles. |
| B 44 miles. | D 100 miles. |
- 24** This diagram is from an American book. The measurement is in inches.



How tall is the dog in centimetres?

- | | |
|----------------|----------------|
| A 12 cm | C 48 cm |
| B 28 cm | D 76 cm |

Questions 25–27 refer to the following information:

Photocopying paper is sold by the ream. A ream is 500 sheets of paper. The most common size of paper used is A4. An A4 sheet measures 297 mm × 210 mm. It is part of the ‘A’ series of paper sizes which is based on the A0 size. An A0 sheet measures 1189 mm × 841 mm and is almost exactly 1 square metre in area.

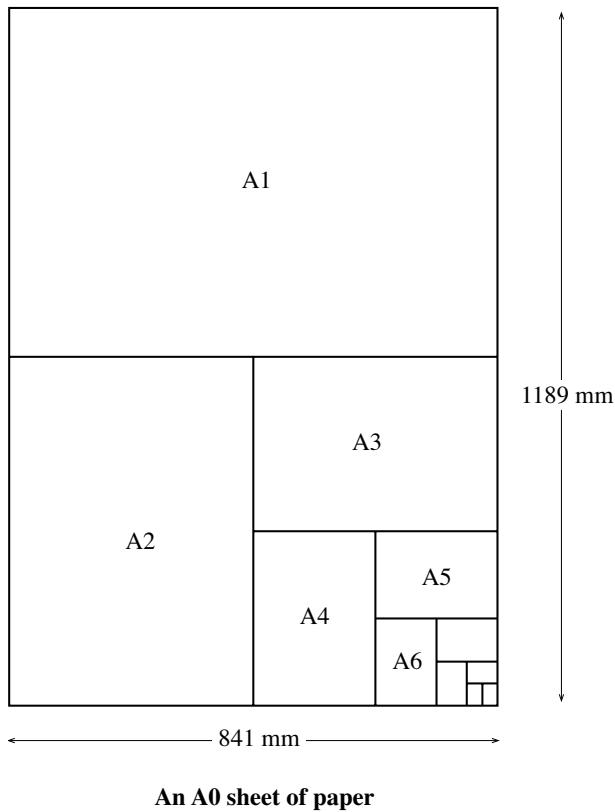

As the diagram shows,

- an A1 sheet is half the area of an A0 sheet
- an A2 sheet is half the area of an A1 sheet
- an A3 sheet is half the area of an A2 sheet
- and so on.

- 25** How many A4 sheets are needed to cover an A0 sheet?
- A** 8
 - B** 16
 - C** 32
 - D** 64
- 26** Most photocopying paper weighs 80 grams per square metre. How much does one sheet of A4 photocopying paper weigh?
- A** 5 g
 - B** 20 g
 - C** 32 g
 - D** 50 g
- 27** The length of the longer side of an A5 sheet is closest to
- A** 420 mm
 - B** 297 mm
 - C** 210 mm
 - D** 149 mm

- 28 A cubic container this size will hold 1000 litres (or 1 kilolitre) of water.

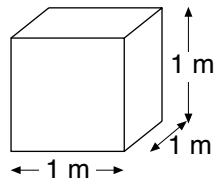

The swimming pool shown is filled to a depth of 2 metres.

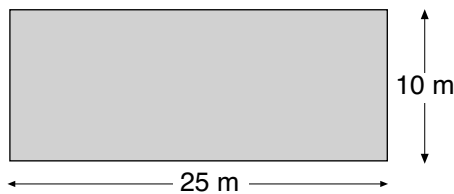

Swimming pool: top view



Swimming pool: side view

How much water is there in the pool?

- A 50 kilolitres
- B 140 kilolitres
- C 250 kilolitres
- D 500 kilolitres

- 29 $57 \times 29 + 57 \times 11 = 57 \times (50 - \Delta)$.

$\Delta =$

- A 0
- B 10
- C 40
- D 319

- 30 Paul is making a cabinet. He has drawn a sketch to show its size.

The timber he needs is 600 mm wide.

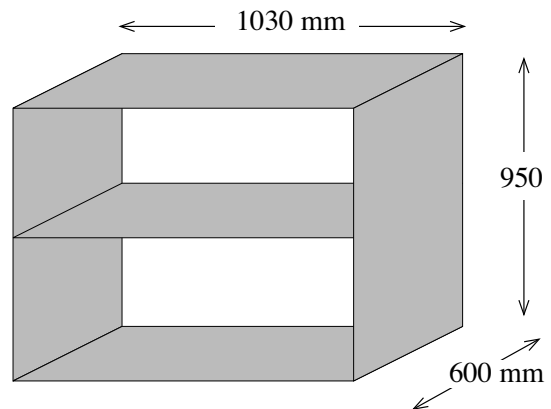

Altogether the length of timber he needs is about

- A 3 metres.
- B 4 metres.
- C 5 metres.
- D 6 metres.

- 31 Gina estimated that it cost her about \$45 per week for petrol for her car. She had the car converted so that it would also run on gas. Gas is much cheaper than petrol so it only cost her about \$20 per week for gas. The conversion cost about \$1000.

How long will it take for the savings in using gas to equal the cost of the conversion?

- A about 15 weeks
- B about 40 weeks
- C about 50 weeks
- D about 65 weeks

Questions 32–33 refer to the following information:

The letter H has half turn symmetry. If it is rotated about its centre through 180° it appears unchanged.

32 Which one of these letters A E S U has half turn symmetry?

- A A
- B E
- C S
- D U

33 Greg is making a crossword puzzle grid with half turn symmetry. He has completed the first four rows. He has two more squares to colour black to complete his grid.

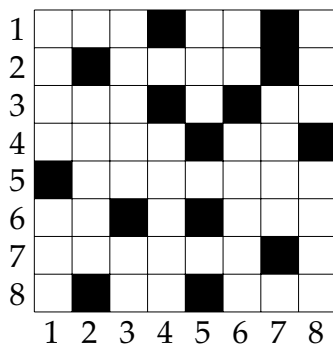

The two squares to colour black are

- A row 5, column 4 and row 7, column 2
- B row 5, column 5 and row 5, column 8
- C row 8, column 7 and row 2, column 4
- D row 4, column 1 and row 5, column 8

34 Note that $100 \div 2.5 = 40$.

So, $10 \div 0.25 =$

- A 0.40
- B 4.0
- C 40
- D 400

35 This is the net for a closed rectangular box.

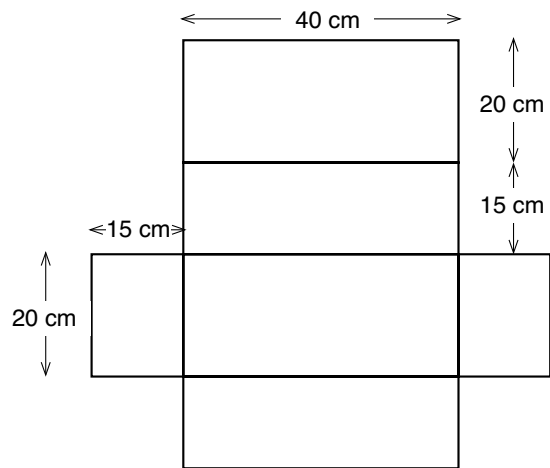

The volume of the completed box will be

- A 280 cubic centimetres
- B 900 cubic centimetres
- C 1 800 cubic centimetres
- D 12 000 cubic centimetres

- 36 The diagram shows the area of one hectare and one acre, drawn to scale.

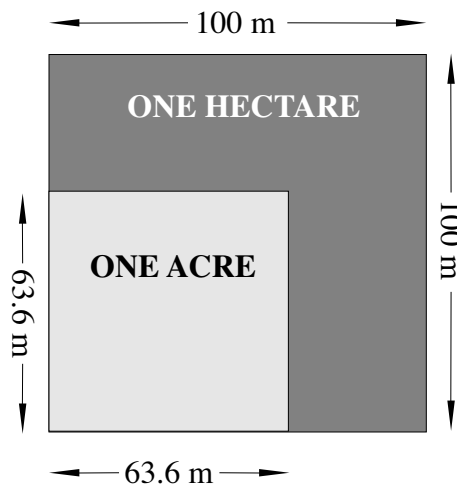

Which of these four areas is the biggest?

- A 200 metres \times 200 metres
 - B 2 hectares
 - C 3 acres
 - D 30 000 square metres
- 37 Zanna is making a magic hexagon using this design and the numbers 1 to 19. The numbers in each diagonal and column must add up to 38.

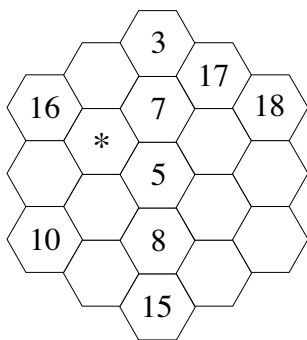

The number that goes at position * is

- A 2
- B 4
- C 12
- D 17

- 38 Trang is helping the P.E. teacher. She wants to fill the long jump pit with sand about 0.3 metres deep.

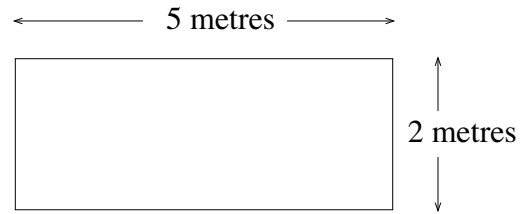

How much sand does she need?

- A 30 cubic metres
- B 20 cubic metres
- C 4 cubic metres
- D 3 cubic metres

**END OF MATHEMATICS
SAMPLE QUESTIONS**

LOOK BACK OVER YOUR WORK

MATHS

| Item | KEY |
|------|-----|
| 1 | B |
| 2 | B |
| 3 | C |
| 4 | B |
| 5 | B |
| 6 | D |
| 7 | C |
| 8 | C |
| 9 | A |
| 10 | A |
| 11 | B |
| 12 | D |
| 13 | A |
| 14 | C |
| 15 | B |
| 16 | C |
| 17 | D |
| 18 | D |
| 19 | A |
| 20 | B |
| 21 | D |
| 22 | D |
| 23 | A |
| 24 | D |
| 25 | B |
| 26 | A |
| 27 | C |
| 28 | D |
| 29 | B |
| 30 | C |
| 31 | B |
| 32 | C |
| 33 | A |
| 34 | C |
| 35 | D |
| 36 | A |
| 37 | A |
| 38 | D |
| 39 | |
| 40 | |